

MDC300-240081 - Brushless DC Controller



FEATURES

- Maximum Current Limit Setting from 2.5 to 7.5 Apk
- Internal/External Potentiometer or Voltage Input Speed Control
- Onboard Potentiometer Ramp Up Adjustment
- 2-Quadrant Operation
- Hall Sensor Feedback
- Constant Velocity Mode
- Short Circuit Protection
- Requires 200-240VAC
- Speed Out, and Fault Out
- Run/Stop, Freewheel and Direction Inputs
- Optically Isolated Inputs and Outputs
- Dual Mounting Option
- Detachable, Screw Type Terminal Blocks
- Covered, Screw Type Strips
- RoHS Compliant



DESCRIPTION

The MDC300-240081 driver is designed to drive DC brushless motors at currents of up to 7.5A peak and 340VDC. Using hall sensor feedback, a constant velocity mode can be selected. The driver is protected against over current (cycle-by-cycle or latched), hall sensor error and under voltage. When an error occurs, a fault light notifies the user. If the fault latch is enabled and an error occurs, the fault output goes low to notify the user. Included on the driver is an internal potentiometer to control the maximum phase current allowed into the motor and an internal potentiometer to control the speed of the motor. An optional external potentiometer or voltage input can be used to control the speed as well. The direction of the motor can be preset by the direction control input or controlled by the external voltage speed input. Other inputs to the drive include a run/stop and a motor freewheel input. An onboard potentiometer sets the ramp up profile from standstill. The run/stop input overrides all other inputs into the driver.

DIMENSIONS

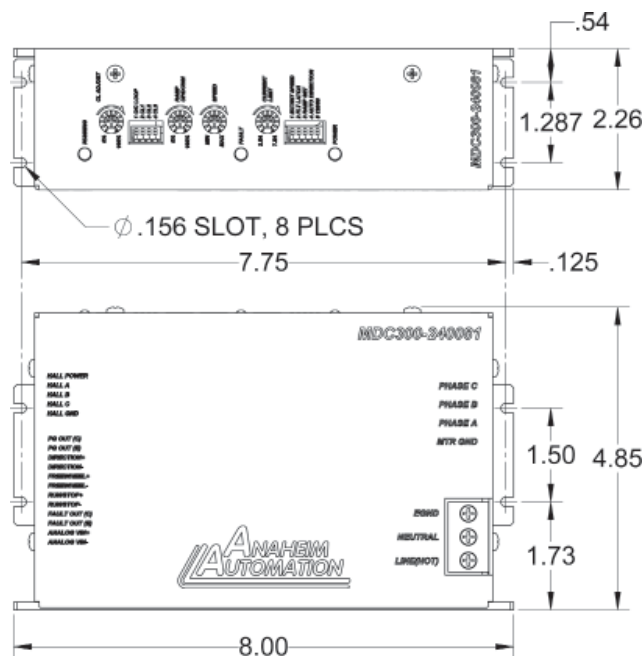

L010469

Control Isolated Inputs: (TB3, Pins 3-8,11,12)	1mA minimum Logic "0" = 3.5 - 8.6 VDC Logic "1" = Open
Power Requirements:	200VAC (min) - 240VAC (max)
Output Current Range:	2.5 - 7.5 Amps (peak) 1.25 - 3.75 Amps (Continuous)
Hall Sensor Power Output:	5V @ 30mA (Max)
Operating Temperature:	Heat Sink: 0°-70°
Control Isolated Outputs: (TB1, Pins 1,2,9,10)	These open collector outputs are able to sink 50mA.
PG Output (TB1, Pin 1-2)	An open collector optically isolated signal pulse out is available at a rate of 4 pulses for 1 revolution of an 8-pole motor, 3 pulses for 1 revolution of a 6-pole motor, and 2 pulses for 1 revolution of a 4-pole motor. 8-pole motor RPM = 15 * PG OUT (in Hz) 6-pole motor RPM = 20 * PG OUT (in Hz) 4-pole motor RPM = 30 * PG OUT (in Hz)
Fault Output: (TB1, Pin 9-10) <i>Enabled when fault latch enabled.</i>	An optically isolated open collector is available to indicated when a fault has occurred. When NO fault occurs, this output will conduct current into the emitter. Care must be take to not pass more than 50mA of current through this transistor. The emitter is also optically isolated.
Output Current Rating:	Adjustable 2.5-7.5 amperes per phase maximum operating peak current (1.25-3.75amperes per phase maximum operating continuous current)
Maximum Closed Loop Motor Speed	2 pole: 30,000 RPM 4 pole: 15,000 RPM 6 pole: 11,250 RPM 8 pole: 7,500 RPM
Maximum Open Loop Motor Speed	50,000 RPM

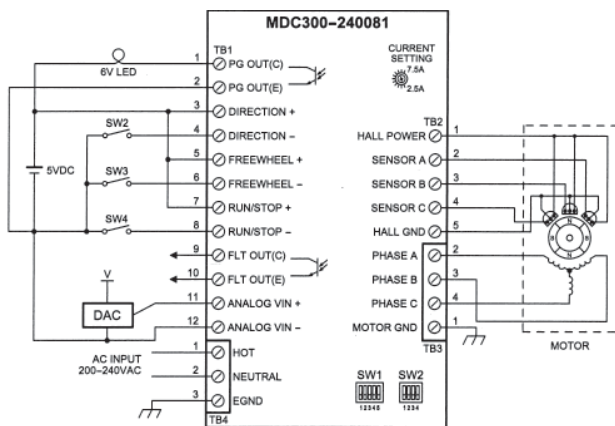

Figure 1: Hook up for current sinking inputs

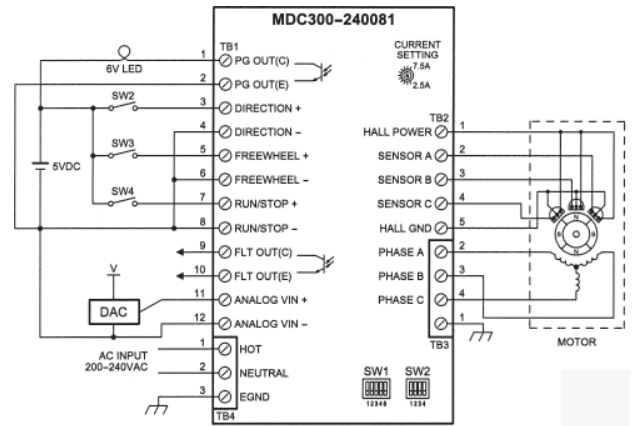

Figure 2: Hook up for current sourcing inputs